

Axe Jig SVA-170

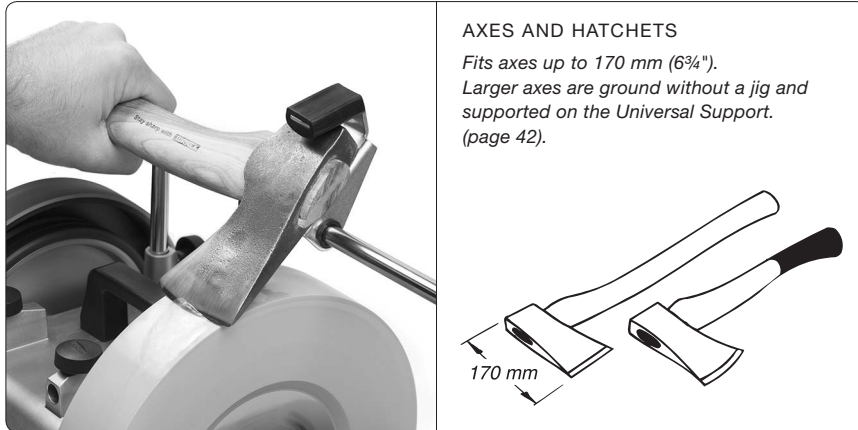

Positioning of Machine

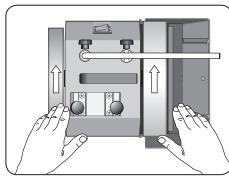

*Grinding direction:
Towards the edge.*

Design

The jig comprises a clamp with a rubber lined, wedge shaped stop, which holds the axe in a fixed position towards the grindstone. The clamp works on the Universal Support, on which it slides across the wheel.

The jig is designed so that the rotation of the wheel presses the axe firmly into the jig. You only need to hold and guide the axe with your hands. This jig only works with the wheel running towards the edge. If necessary, the honing wheel can be removed to allow clearance for the axe handle.

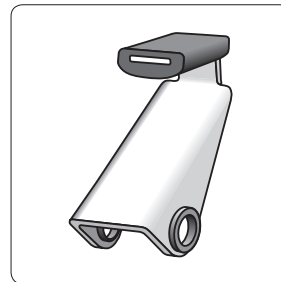

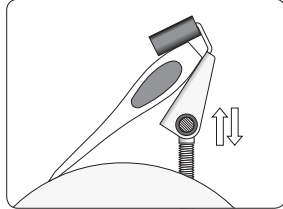

Place the axe into the jig. Set the edge angle by adjusting the Universal Support. Either at the original angle using the Marker Method or at a new angle using the AngleMaster WM-200.

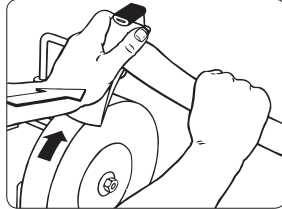

Press with your palm on the axe, close to the wheel. The axe will automatically be pressed up against the stop in the jig and the grinding is most efficient.

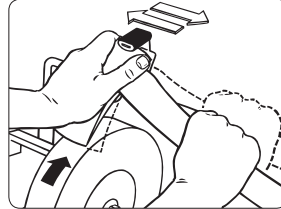

Follow the shape of the edge (straight or curved) during grinding by raising or lowering the handle. Let the jig slide sideways on the Universal Support so that the wheel wears evenly.

Edge Angle

The edge angle of a carpenter's axe or hatchet should be 25–30°, depending on the hardness of the wood. Grind the edge with a smaller bevel angle on the side towards the wood than on the other side. This longer bevel gives you a good support towards the wood. Also, as the axe works closer to the surface of the wood, the cutting will be more effective and easier to control.

A felling axe and a hunting axe must have a larger edge angle, 30–40°, so that the edge is more durable. Round off the heels of the bevels and the axe cuts more easily. This is done by lowering the Universal Support and grinding in two steps.

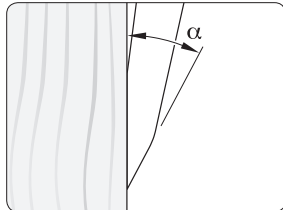

Put a longer bevel on the wood-side on a carpenter axe.

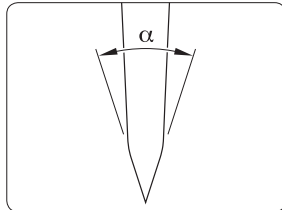

A felling axe should have an edge angle (α) of 30–40°. Round off the heels and the axe cuts more easily.

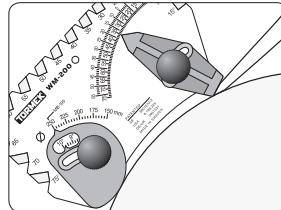

You can set and measure the edge angle with the AngleMaster WM-200.

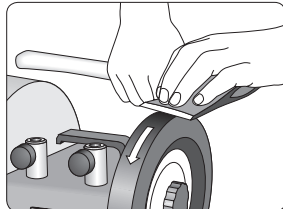

Honing and polishing the bevels on the leather honing wheel makes the edge cut more easily and the sharpness will stay longer. Always hone away from the edge.